

HGB Fluid Regulators

Important: Before using this equipment, read all safety precautions and instructions. Keep for future use.

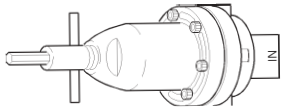

Model HGB-502
 Regulator Assembly
 Only

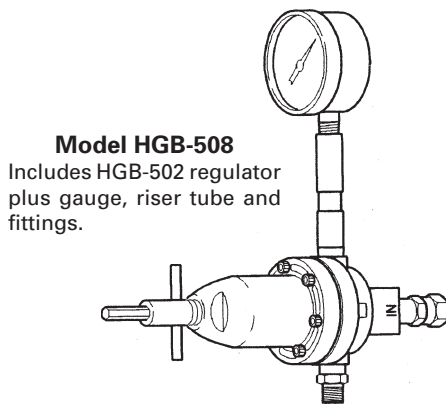

Model HGB-508

Includes HGB-502 regulator plus gauge, riser tube and fittings.

SPECIFICATIONS:

Height: 5" (excluding adjusting key)
 Width: 2-7/8"

Inlet Pressure		Regulated	Max . Fluid	Connections
Max.	Min.	Outlet Press.	Flow	
175 psi	50 psi	10-75 psi	8 gal/min.	3/8" NPT(F)

Maximum temperature 180°F.

INSTALLATION

The HGB regulator is provided with two side outlet ports and one bottom inlet port, all 3/8" NPT(F). The regulator may be installed either vertically or horizontally for flexibility of installation. In either case, riser and gauge should be mounted vertically. The HGB-508 includes gauge, riser tube and fittings factory installed.

Since the gauge operates on air trapped in the riser, a rise is always necessary. Any leaks in riser or gauge connections will permit this trapped air to escape thus allowing paint to get into the gauge causing damage.



It is recommended that at initial installation the material supply line should not be flushed through the regulator because pipe compound, chips, scale, etc., may lodge in the regulator valve assembly.

See "ACCESSORIES" section for connections for riser, gauge, tee, inlet swivel and ball valves.

OPERATION

Fluid pressure adjustment is done with a removable key (1). Insert large end of key into top of regulator. Turn clockwise to increase fluid pressure, counterclockwise to decrease fluid pressure.

Fluid pressure adjustment can also be accomplished remotely with air control:

1. Turn adjusting key (1) fully counterclockwise turning the regulator off.
2. Remove adjusting key (1).
3. Install a 1/4" NPT(M) fitting H-2008 for air hose connection.
4. Use a regulated air supply to adjust fluid pressure regulator.

PREVENTIVE MAINTENANCE

Periodic cleaning of regulator with a solvent compatible with the material being used is recommended.

To clean material from the regulated material line and the regulator, these steps should be followed:

1. Relieve supply line pressure.
2. Using the small end of the adjusting key (1), engage the regulator and screw it down tight. This holds the valve off its seat. Also, the key may be used in this position to prevent waste from entering the regulator when spray booth is cleaned.
3. Blow material back through the regulated line by introducing air pressure into the line down stream from the regulator. With spray gun attached, this can be done by loosening air cap ring on gun, holding cloth over air cap and pulling trigger. This forces air in a reverse path through spray gun and air forces material back through regulated material line.

4. Periodically clean exterior of regulator with solvent soaked cloth.

PARTS REPLACEMENT

The HGB regulator may be serviced without removing it from the line.

Note

Relieve line pressure before servicing regulator.

Remove six socket head cap screws (2) with a 5/32" Allen wrench. The small end of the adjusting key (1) may be used for this purpose.

To Replace Diaphragm:

1. The diaphragm socket (B) has an arrow  stamped on top. Curl the edge of the diaphragm up where the arrows point.
2. Slip the diaphragm assembly out from under the valve stem nut (C) so the nut is released from the socket (B).
3. Remove nut (A) and pull off diaphragms (7). Install 2 new diaphragms over threaded end of the socket (B). Convex sides of each diaphragm must be toward threaded end.
4. Apply retaining compound to male threads as shown and install nut (A).
5. Install diaphragm into body by again curling the edges of the diaphragms.
6. Slip socket (B) under valve stem nut (C).
7. Reassemble regulator body. Tighten all six cap screws evenly to 65 to 75 in./lbs. torque.

To Service Valve Assembly:

1. Valve assembly can be removed from the body with a 3/4" socket wrench.
2. Remove nut (C) and discard stem and seat (9).
3. Reassemble. Apply retaining compound to male threads on stem and tighten nut as shown.
4. When reinstalling, tighten valve assembly to 20 to 25 in./lbs. torque.

TROUBLESHOOTING		
CONDITION	CAUSE	CORRECTION
Regulated pressure creep.	Improper seating of valve stem on seat. Diaphragm leaking. Damaged valve seat.	Be sure stem and seat are not damaged, worn or dirty. Replace. Replace seat and stem.
Regulated pressure drop.	Restriction in main material line or at valve inlet. Damaged diaphragm.	Remove restriction. Replace.
Fluid leakage from under bonnet.	Loose cap screws (2). Damaged diaphragm.	Tighten all six cap screws evenly to 65 to 75 in./lbs. torque. Replace.

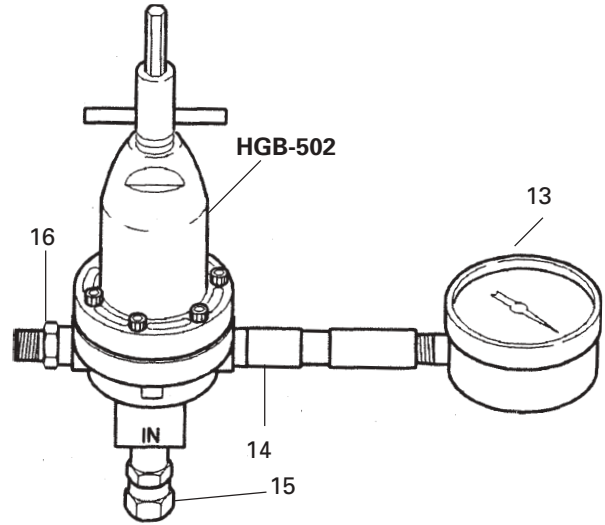
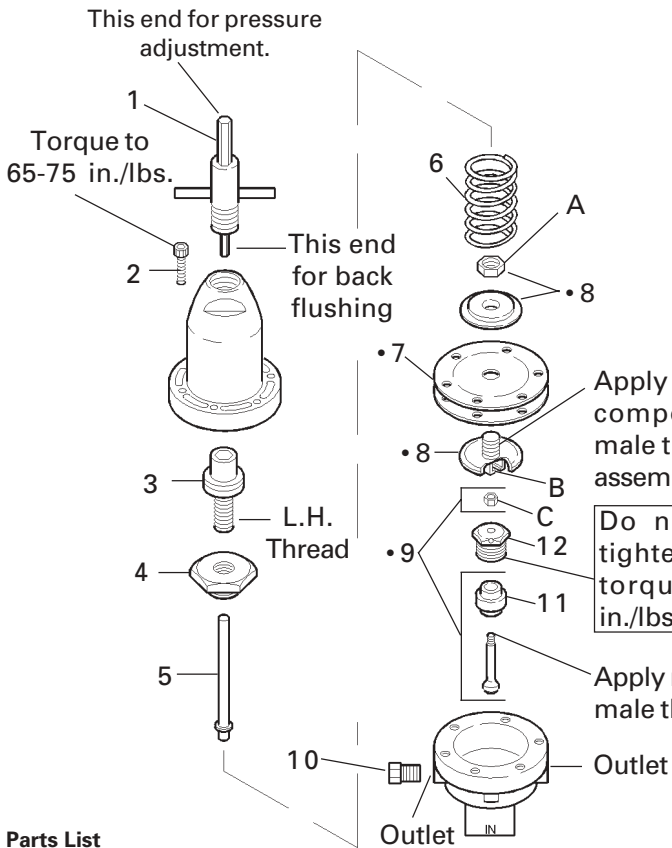

Parts List

Ref. No.	Replacement Part No.	Description	Individual Parts Req.
1	HGB-404	Adjusting Key	1
2	SSF-3167-K6	Cap Screw (Kit of 6)	6
3	HGB-408	Adjusting Screw Assembly	1
4	HGB-7	Adjusting Nut	1
5	HGB-403	Pin Assembly	1
6	HGB-13	Spring	1
+7	HGB-16-K10	Diaphragm Kit, Nylon II (Kit of 10)	2
•8	KK-4216	Diaphragm Hardware Kit	1
•9	KK-4217	Valve Repair Kit	1

Ref. No.	Replacement Part No.	Description	Individual Parts Req.
*10		S/S Plug, 3/8" NPT(M)	1
11	HGB-9-1-K5	Valve Seat Kit (Kit of 5)	1
12	HGB-24	Seal Retainer	1
13	GA-333	Gauge	1
14	HGB-14	Riser Tube, Stainless Steel	1
15	PLH-6SN-6TSS	Swivel Fitting, S.S.	1
16	PLH-6-6T-SS	Fitting, Stainless Steel	1

- All kits contain parts shown plus retaining compound for use at assembly.
- + Kit contains 10 diaphragms. Only 2 are used in regulator. Diaphragms are only available in kit form.
- * Purchase locally.

ACCESSORIES

HGB-14 Riser Tube

3/8" NPT(M) x 1/4" NPT(F) Stainless Steel, 3-1/2" for elevated mounting of gauge

GA-333 Air Pressure 0-100 PSI Gauge

1/4" NPT(M), 2" diameter, requires riser tube.

H-2008 Coupling

1/4" NPS(M) x 1/4" NPT(M) for adapting regulator to remote air control.

VA-527 Ball Valve S/S

3/8" NPS(M) x 3/8" NPT(M)

WARRANTY

This product is covered by Devilbiss' 1 Year Limited Warranty. See SB-1-000 which is available upon request.

DeVILBISS WORLDWIDE SALES AND SERVICE LISTING - www.devilbiss.com

INDUSTRIAL FINISHING - DeVilbiss has authorized distributors throughout the world. **FOR TECHNICAL ASSISTANCE OR THE DISTRIBUTOR NEAREST YOU, CALL TOLL FREE 1-888-992-4657 (U.S.A. AND CANADA ONLY). FOR LOCAL CALLS, SEE LISTING BELOW.**

U.S./Canada Sales & Customer Service Office
 GLENDALE HEIGHTS, IL 60139

Address
 195 Internationale Blvd.

Telephone No.
 (630) 237-5000

